

YJ80(2P)

DIBUJO

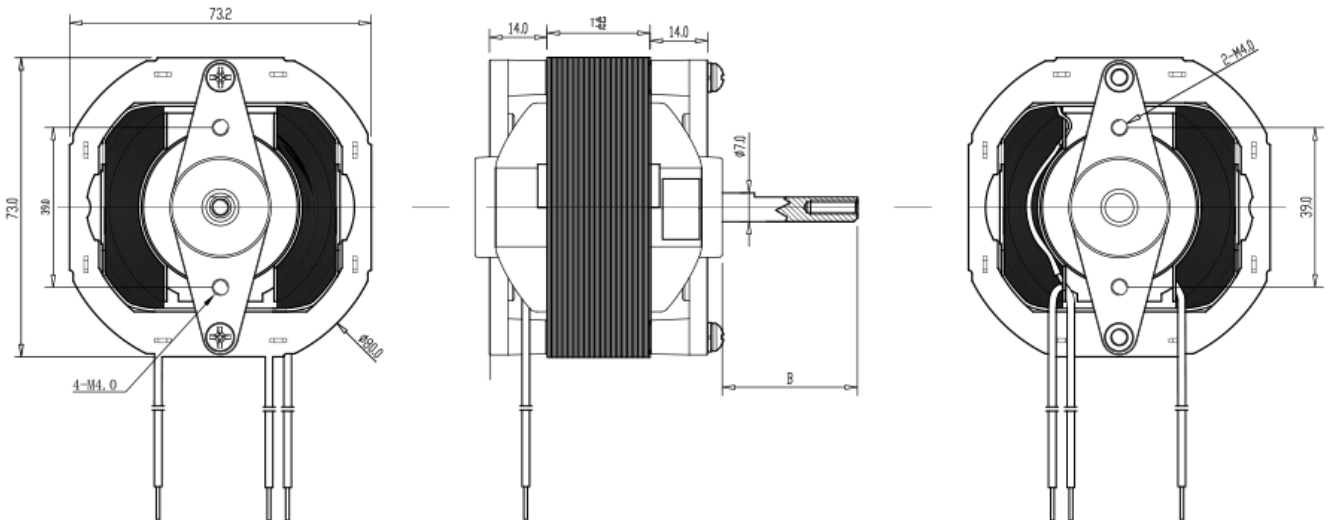

CARACTERISTICAS

TYPE	VOLTAGE V AC	FREQUENCY Hz	CURRENT A	POWER W	SPEED r/min	SHAFT EXTENSION mm	STATOR THICKNESS mm	ROTATION
YJ-80-25	220-240	50	0.21	27	2880	<90	25	CW/CCW
	110-120	60	0.35	23	3480	<90	25	CW/CCW