

YJ52

DRAWING

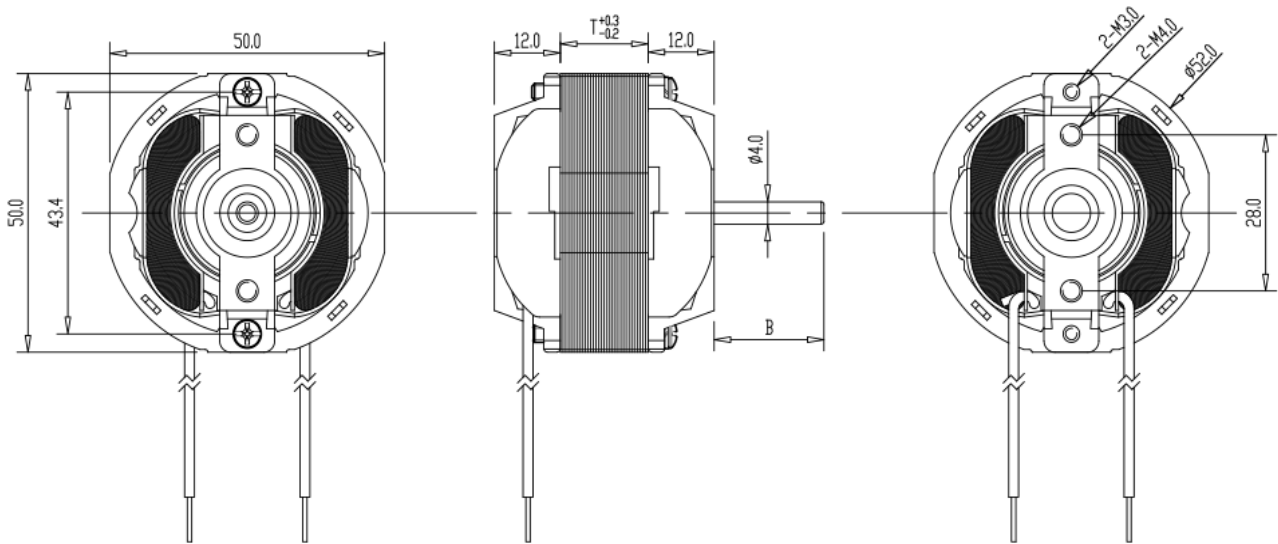

CARACTERÍSTICAS

TYPE	VOLTAGE V AC	FREQUENCY Hz	CURRENT A	POWER W	SPEED r/min	SHAFT EXTENSION mm	STATOR THICKNESS mm	ROTATION
YJ-52-16	220-240	50	0.11	15	2800	<68	16	CW/CCW
YJ-52-20	220-240	50	0.13	17	2830	<68	20	CW/CCW
YJ-52-25	220-240	50	0.15	19	2860	<68	25	CW/CCW