

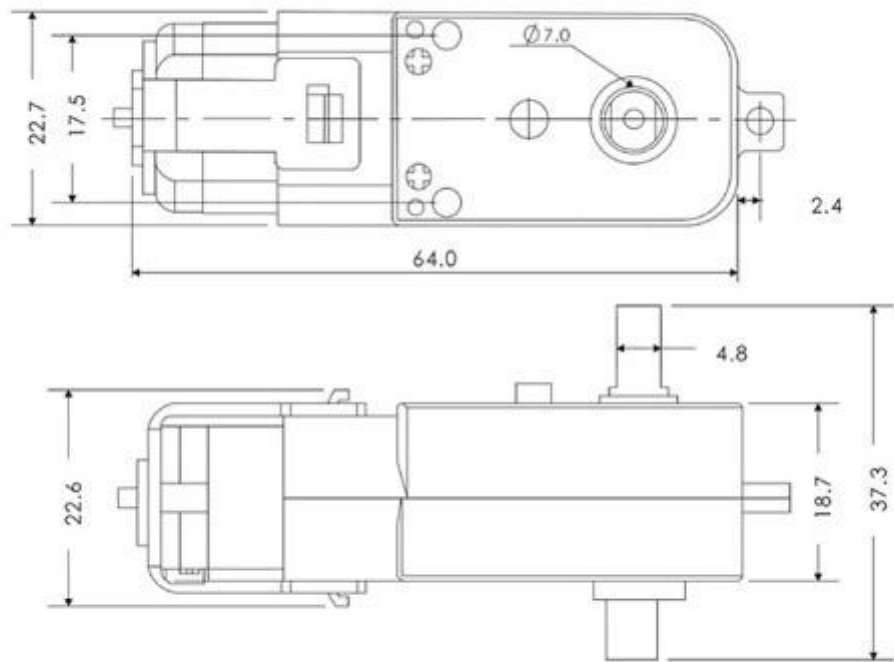

**GP01D-A130**

**DIBUJO**



UNIT : Millimeters WEIGHT : 30 g (APPROX)

**CARACTERISTICAS**

MODEL	REDUCTION RATIO	VOLTAGE		NO LOAD		AT MAXIMUM EFFICIENCY				STALL		
		OPERATING RANGE	NOMINAL	SPEED	CURRENT	SPEED	CURRENT	TORQUE	OUTPUT	TORQUE	CURRENT	
		VDC	VDC	RPM	A	RPM	A	mN.m   g.cm	W	mN.m   g.cm	A	
GP01D-A130	14150	120	3.0~12.0	4.5	100	0.20	87	0.50	66.1   675		264.5   2700	1.25
	18100	220	3.0~12.0	3.0	50	0.20	40	0.60	120.0   1230		392.0   4000	2.10