

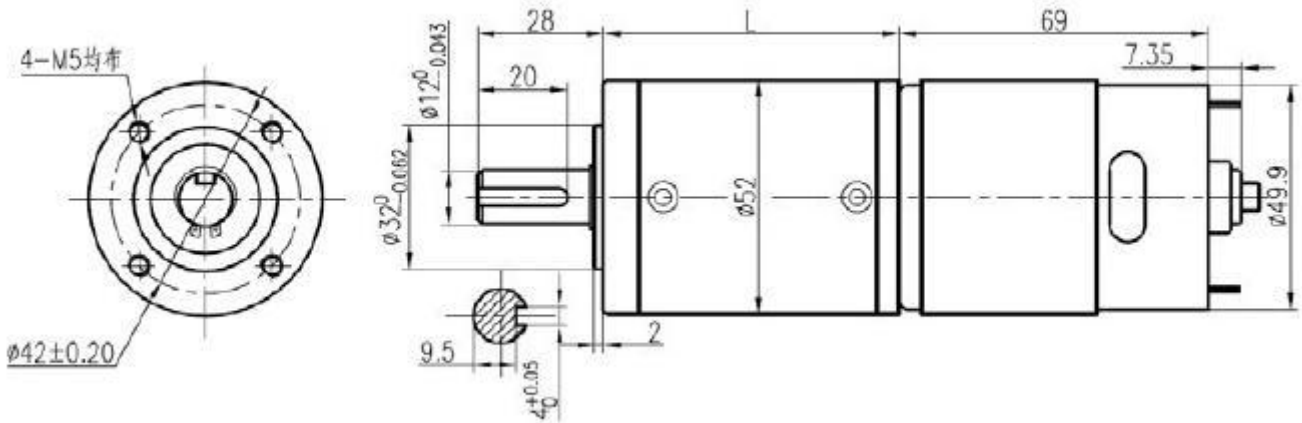

GMP52-977SMP

DIBUJO



UNIT : Millimeters WEIGHT : 600 g (APPROX)

CARACTERISTICAS

MODEL	REDUCTION RATIO	VOLTAGE		NO LOAD		AT MAXIMUM EFFICIENCY				STALL				
		OPERATING RANGE	NOMINAL	SPEED	CURRENT	SPEED	CURRENT	TORQUE	OUTPUT	TORQUE	CURRENT			
		VDC	VDC	RPM	A	RPM	A	mN.m	g.cm	W	mN.m	g.cm	A	
GMP52-977SMP	4051	13	12-28	24	40	1.2	32	8.1		165000	110		965000	55