

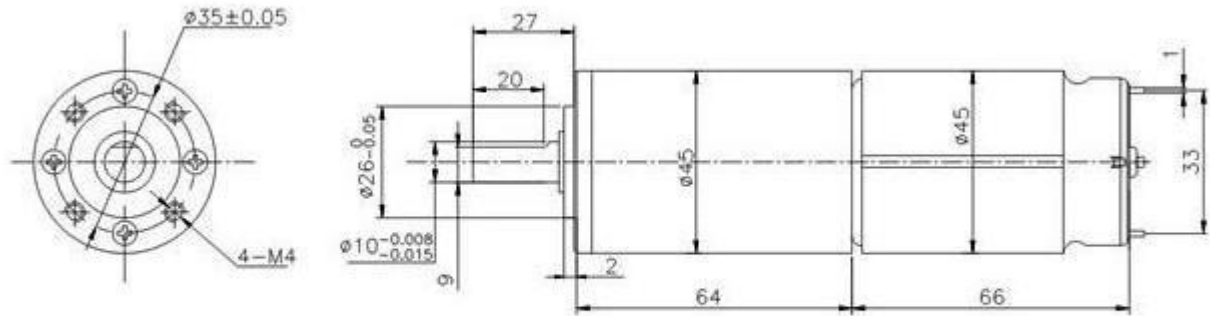

GMP45-755SA

DIBUJO



UNIT : Millimeters WEIGHT : 460 g (APPROX)

CARACTERISTICAS

MODEL	REDUCTION RATIO	VOLTAGE		NO LOAD		AT MAXIMUM EFFICIENCY				STALL				
		OPERATING RANGE	NOMINAL	SPEED	CURRENT	SPEED	CURRENT	TORQUE	OUTPUT	TORQUE	CURRENT			
		VDC	VDC	RPM	A	RPM	A	mN.m	g.cm	W	mN.m	g.cm	A	
GMP45-755SA	3174	71	9.0-24.0	12.0	39	0.2	29	0.7	1960	20000	5.6	14710	150000	1.9