

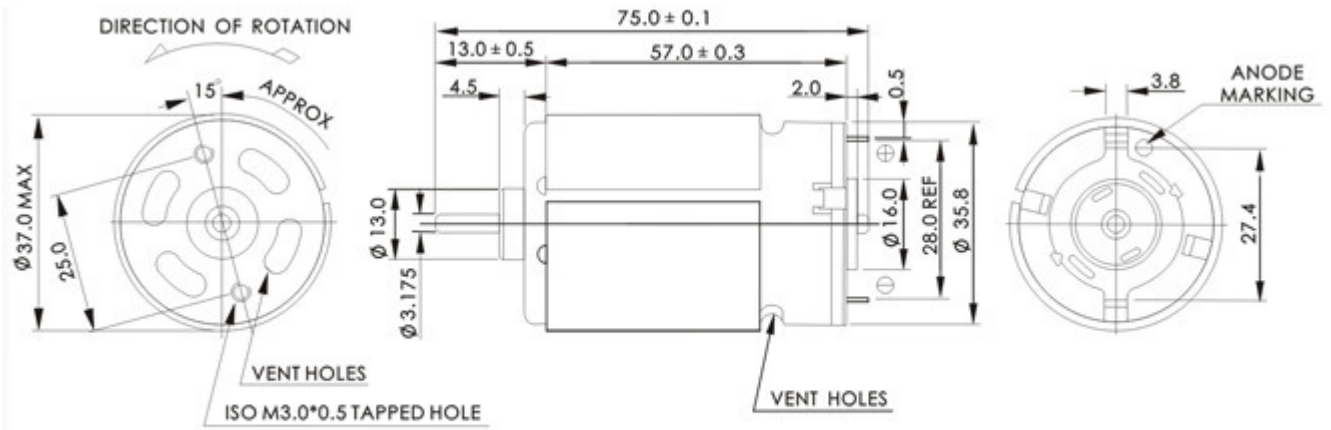

ARS-555SP

DIBUJO



UNIT:Millimeters

WEIGHT:215g(APPROX)

CARACTERISTICAS

MODEL	VOLTAGE		NO LOAD		AT MAXIMUM EFFICIENCY					STALL			
	OPERATING RANGE	NOMINAL	SPEED	CURRENT	SPEED	CURRENT	TORQUE	OUTPUT	TORQUE	CURRENT			
	VDC	VDC	RPM	A	RPM	A	mN.m	g.cm	W	mN.m	g.cm	A	
ARS-555SP	4525	4.5-18.0	12.0	12400	0.66	10730	4.20	33.23	339	37.0	246.1	2510	27.0
	5016	7.2-12.0	12.0	20000	1.50	17800	7.20	31.37	320	58.4	245.1	2500	46.0

CURVA

