

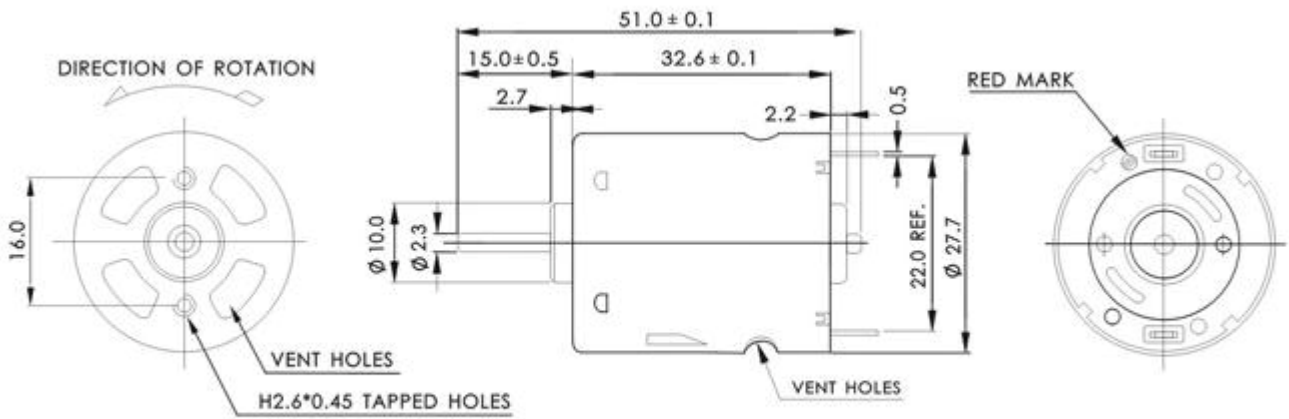

ARS-365SM

DIBUJO



UNIT : Millimeters WEIGHT : 55 g (APPROX)

CARACTERÍSTICAS

MODEL	VOLTAGE		NO LOAD		AT MAXIMUM EFFICIENCY				STALL				
	OPERATING RANGE	NOMINAL	SPEED	CURRENT	SPEED	CURRENT	TORQUE	OUTPUT	TORQUE	CURRENT			
	VDC	VDC	RPM	A	RPM	A	mN.m/g.cm	W	mN.m/g.cm	A			
ARS-365SM	14190	12.0-36.0	24.0	10200	0.08	8160	0.36	5.88	60	5.00	29.41	300	1.5
	13175	8-18	12.0	5280	0.07	4125	0.24	3.43	35	1.48	15.69	160	0.85

CURVA

