

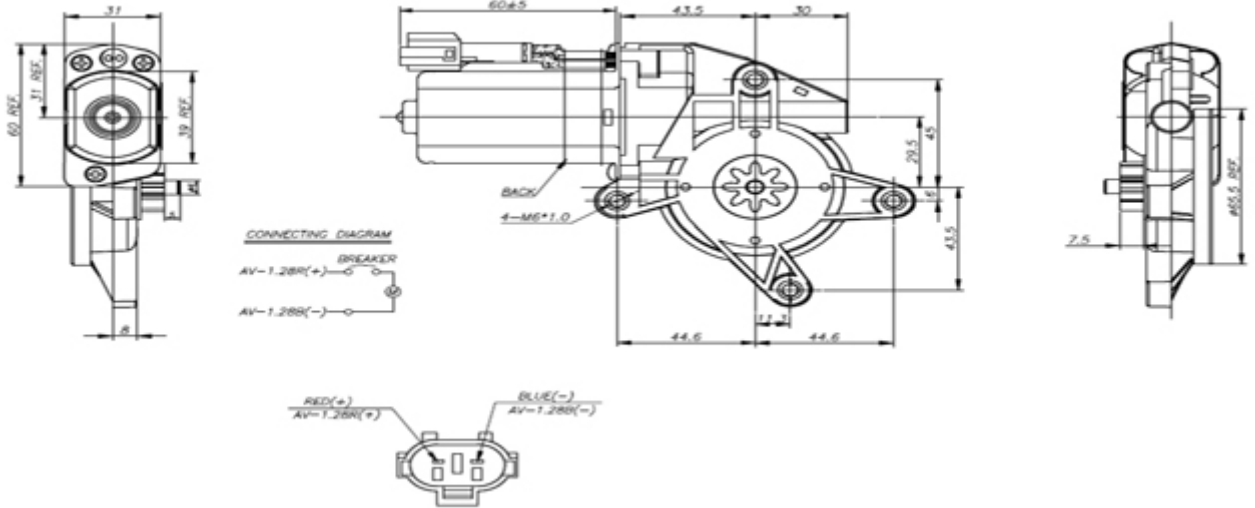

AGP-578S-4720-VER

DIBUJO



CARATTERISTICAS

MODEL	REDUCTION RATIO	VOLTAGE		NO LOAD		AT MAXIMUM EFFICIENCY				STALL		
		OPERATING RANGE	NOMINAL	SPEED	CURRENT	SPEED	CURRENT	TORQUE	OUTPUT	TORQUE	CURRENT	
		VDC	VDC	RPM	A	RPM	A	mN.m/g.cm	W	mN.m/g.cm	A	
AGP-578S-4720-VER	VER 50:1~100:1	12		95	2.0	70	7.5	6		7.0		25

CURVA

CURVE CARATTERISTICHE 13.5 V RESIST.LINEA 0.15 ohm (B)

