

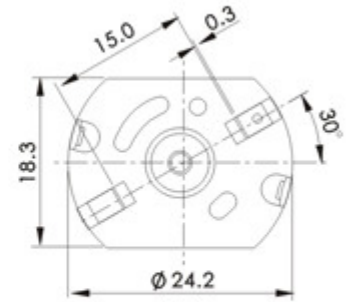

AFK-280SA

DIBUJO

DIRECTION OF ROTATION

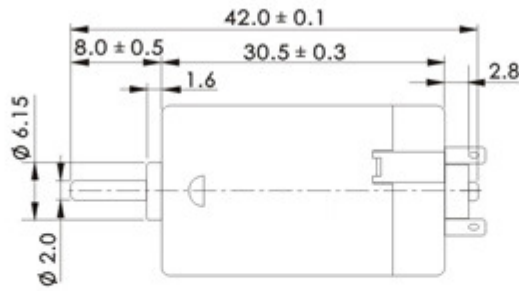
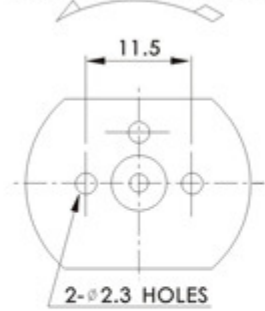

UNIT: Millimeters

WEIGHT: 42g (APPROX)

CARACTERISTICAS

MODEL	VOLTAGE		NO LOAD		AT MAXIMUM EFFICIENCY					STALL			
	OPERATING RANGE	NOMINAL	SPEED	CURRENT	SPEED	CURRENT	TORQUE	OUTPUT	TORQUE	CURRENT			
	VDC	VDC	RPM	A	RPM	A	mN.m	g.cm	W	mN.m	g.cm	A	
AFK-280SA	07550	12.0-24.0	18.0	5600	0.023	4326	0.078	1.59	16.2	0.72	6.96	71.0	0.265
	12280	6.0-24.0	12.0	7500	0.04	6210	0.19	2.11	21.5	1.37	12.55	125	0.93

CURVA

