

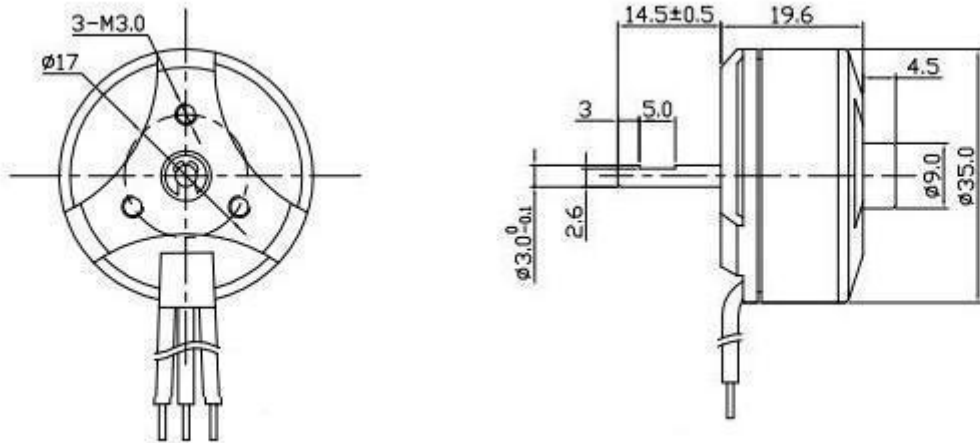

ABL-RC3520

DIBUJO



UNIT : Millimeters WEIGHT : 58 g (APPROX)

CARACTERÍSTICAS

MODEL	VOLTAGE		NO LOAD			AT LOAD				STALL			
	OPERATING RANGE	NOMINAL	SPEED	CURRENT	SPEED	CURRENT	TORQUE	OUTPUT	TORQUE	CURRENT			
	VDC	VDC	KV	RPM	A	RPM	A	mN.m	g.cm	W	mN.m	g.cm	A
ABL-RC3520	01	9~15	12.0	680	8160	0.45		4.1		48			
	02	6~12	9.0	900	8160	0.35		3.1		28			