

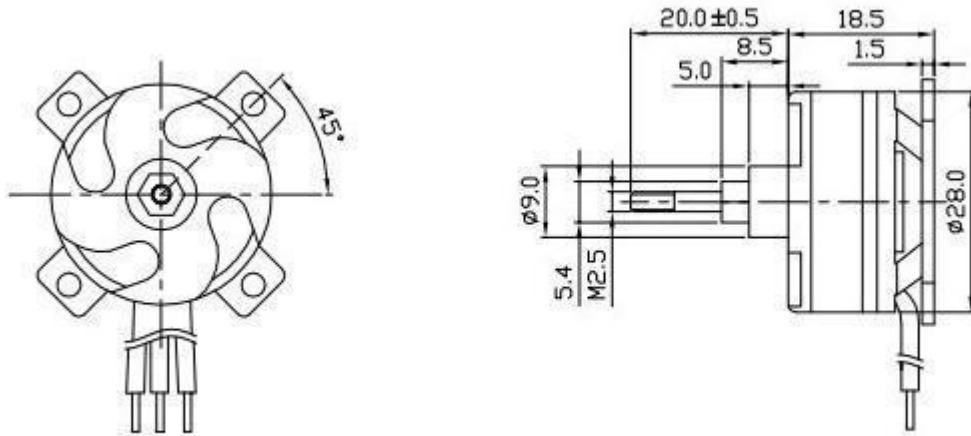

ABL-RC2819

DIBUJO



UNIT : Millimeters WEIGHT : 31 g (APPROX)

CARACTERISTICAS

MODEL	VOLTAGE		NO LOAD			AT LOAD				STALL				
	OPERATING RANGE	NOMINAL	SPEED		CURRENT	SPEED	CURRENT	TORQUE	OUTPUT	TORQUE	CURRENT			
	VDC	VDC	KV	RPM	A	RPM	A	mN.m	g.cm	W	mN.m	g.cm	A	
ABL-RC2819	01	5~10	7	1500	10500	0.5		3.0		470	20			