

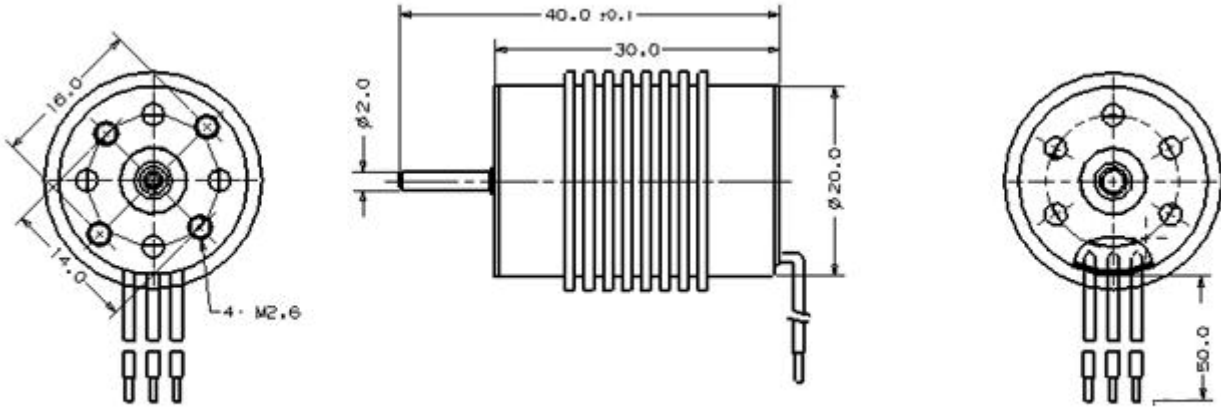

ABL-RB2030

DIBUJO



UNIT : Millimeters WEIGHT : 25 g (APPROX)

CARACTERISTICAS

MODEL	VOLTAGE		NO LOAD			AT LOAD				STALL	
	OPERATING RANGE	NOMINAL	SPEED		CURRENT	SPEED	CURRENT	TORQUE	OUTPUT	TORQUE	CURRENT
	VDC	VDC	KV	RPM	A	RPM	A	mN.m g.cm	W	mN.m g.cm	A
ABL-RB2030	01	5~10	7.4	5300 39220	0.8		8.0		60		
	02	5~10	7.4	6300 46620	1.0		12.0		80		