

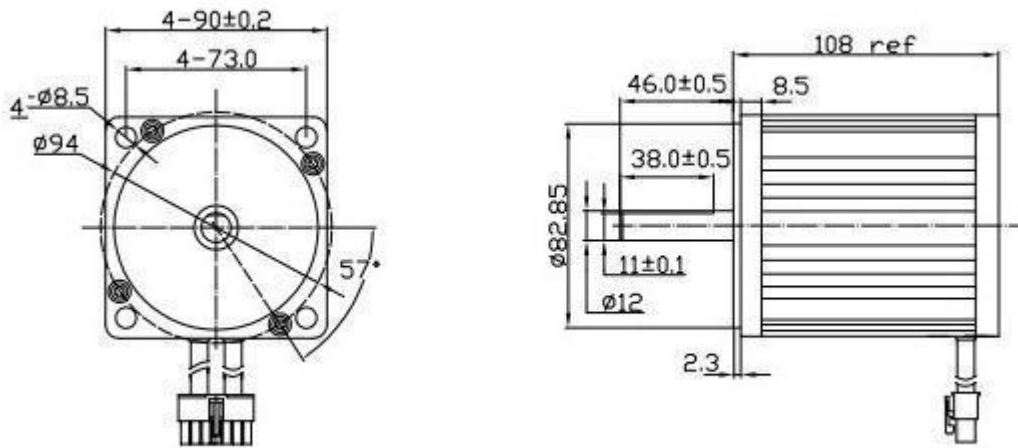

ABL-FB90108

DIBUJO



UNIT : Millimeters WEIGHT : 2240 g (APPROX)

CARACTERISTICAS

MODEL	VOLTAGE		NO LOAD			AT LOAD				STALL	
	OPERATING RANGE	NOMINAL	SPEED	CURRENT	SPEED	CURRENT	TORQUE	OUTPUT	TORQUE	CURRENT	
	VDC	VDC	KV RPM	A	RPM	A	mN.m g.cm	W	mN.m g.cm	A	
ABL-FB90108	01	20-30	24	4000	1.8	3000	22	1274	400		
	02	150-230	220	5000	0.4	4000	1.2	490	200		